

## Bio-mite

### BM4

Our range of Bio-mites are wastewater treatment plants that process wastewater to a specified quality, typically to reuse for irrigation and other non-potable applications.

#### Side view

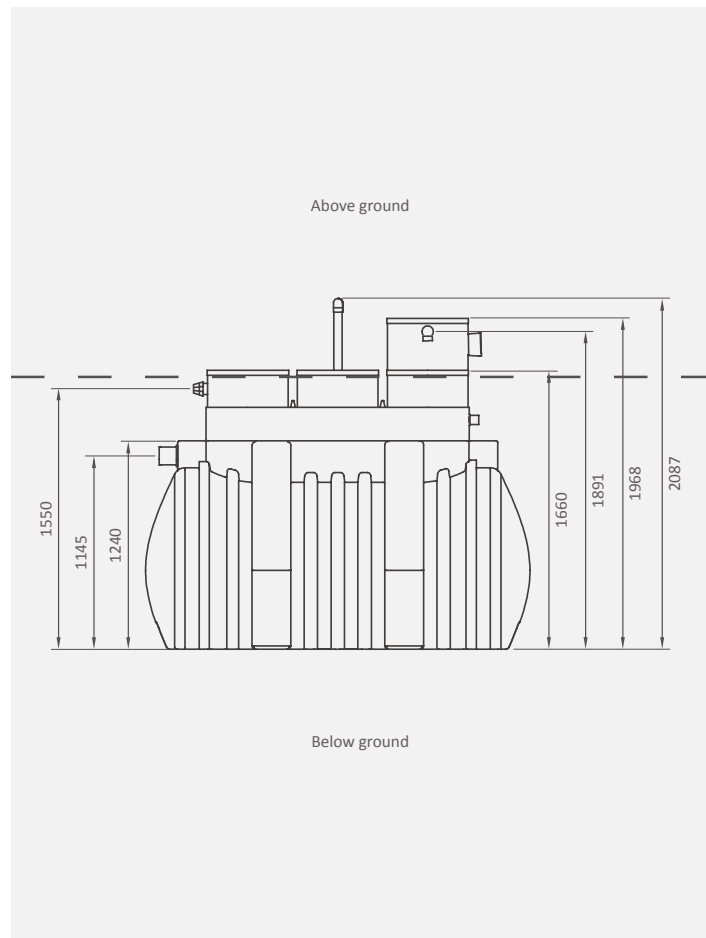

#### Front view

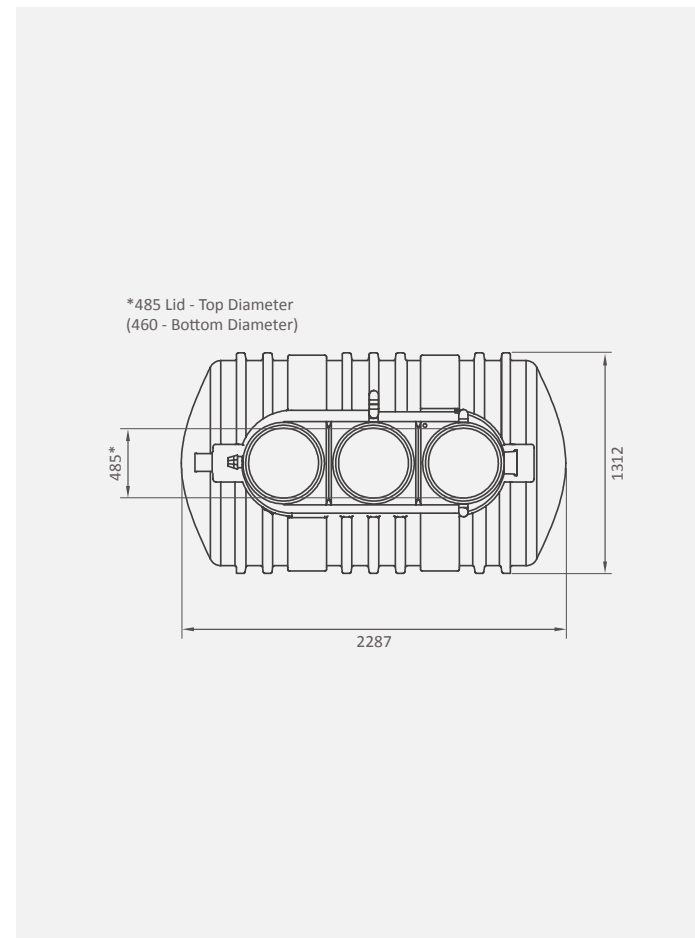

#### Product specifications:

##### Application:

- Below ground wastewater treatment plant
- Allows you to manage and safely reuse domestic wastewater for non-potable applications

##### Capacity:

- Up to 4 people (1KL/day)

##### Loading rate:

- 0.24kg/day (B.O.D./day)

##### Electricity use:

- 0.61kW

##### Supplied with:

- 1) 2x 460mm lids complete with:
  - 200mm high lid extensions
- 2) 1x 460mm lid complete with:
  - 200mm plus 300mm high lid extension
- 3) 50mm breather pipe
- 4) 1x inner chamber with all required internal plumbing
- 5) Inlet fitted with:
  - 110mm junction
  - 110mm screw cap
- 6) Outlet fitted with:
  - 40mm female compression fitting
  - 50mm PVC single socket (emergency overflow)
  - Chlorine dispenser with cartridge
  - Submersible pump (DAB Feka 550 VS)
- 7) Electrical components:
  - Hi-blow Blower
  - PS2 Box
  - Double wall plug

#### Availability:

Standard colour ●

#### 10-year guarantee\*

\* This guarantee excludes all electrical components, these carry the supplier guarantees which are available on request.

Dimensions are in millimeters and the drawings are drawn on a scale of 1:50. The design is the property of Calcamite.